

12V C.C. - D.C.

VA09-AP8/C-54A
VA09-AP8/C-54S

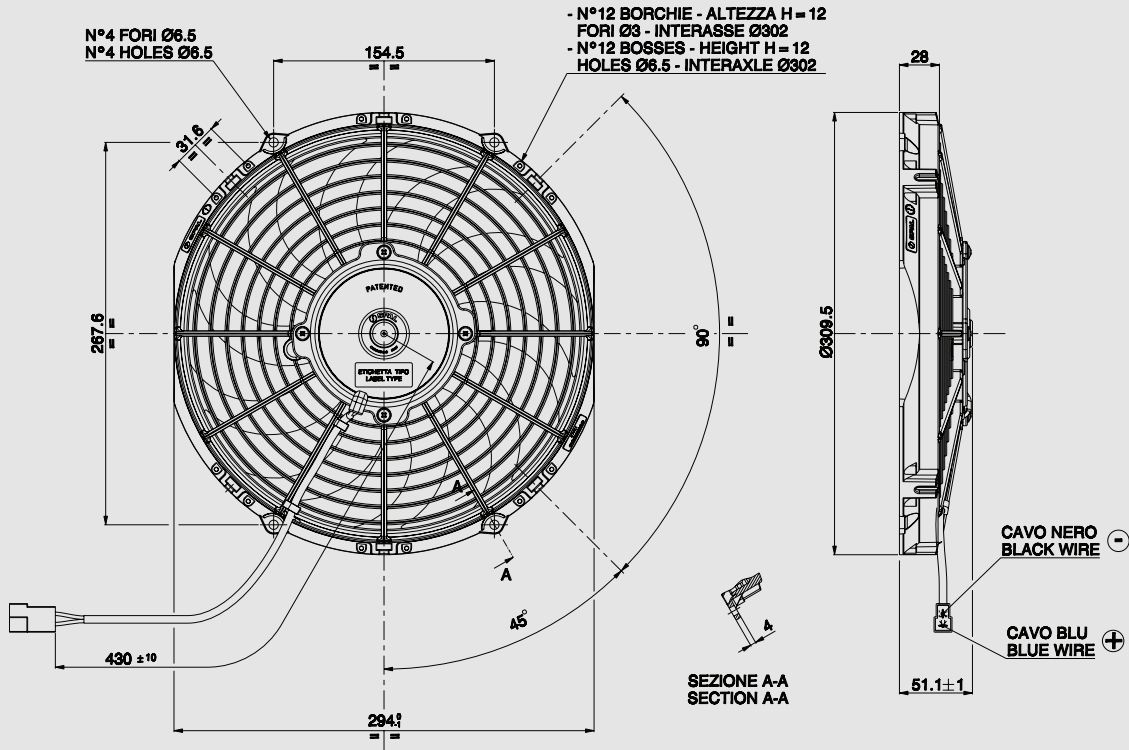

AMP connector Code 180908
 AMP terminal Code 42098-2
 Suggested mounting torque: 3(+1/-0) Nm with screw M5
 Weight 1,1 Kg. approx.

Connettore AMP Cod. 180908
 Terminali AMP Cod. 42098-2
 Coppia di serraggio consigliata: 3(+1/-0) Nm con vite M5
 Peso 1,1 Kg. circa

Ø 280 mm
 Ø 11"

suction / aspirante

blowing / soffiante

PRODUCT FEATURES
 CARATTERISTICHE PRODOTTO

Static pressure Pressione statica mm H ₂ O	suction / aspirante			blowing / soffiante			Static pressure Pressione statica mm H ₂ O
	Airflow Portata m ³ /h	Current input Corrente assorbita A	Airflow Portata CFM	Airflow Portata m ³ /h	Current input Corrente assorbita A	Airflow Portata CFM	
0	1320	6,4	779	1410	6,4	832	0
2,5	1190	6,7	702	1310	6,7	773	0,1
5	970	6,6	572	1060	6,9	625	0,2
7,5	660	6,5	389	820	7,0	484	0,3
10	440	6,7	260	490	6,7	289	0,4
12,5	260	6,8	153	220	6,4	130	0,5
15	0	6,7	0	0	6,5	0	0,6

Waterproof motor, IP 68 Motore chiuso, IP 68	✓
Low noise / Bassa rumorosità	✓
Long life / Lunga durata	✓
LL and VLL version* Versione LL e VLL*	✓
Waterproof connector Connettori a tenuta stagna	✓
Accessories: all the fixing kits Accessori: tutti i kit di fissaggio	✓

* for OEM applications only. ✓ = Standard feature
 * per applicazioni OEM Caratteristiche standard

✓ = Available upon request
 Disponibile su richiesta

Test voltage 13 V. d.c. - Tensione di prova 13 V. c.c.