

The world's first universal-fit, automotive Electric Water Pump. Suitable for naturally-aspirated and turbo engines up to 3 litres.



## Technical specifications

Operating voltage	3V DC to 15V DC
Maximum current	7.5A
Flow rate (max)	80 L/min (1268 US gal/hr) @ 13.5V DC
Operating temperature	-20° to 130°C (-4° to 266°F)
Pump design	Clockwise centrifugal with volute chamber
Motor life	3,000 hours continuous at 80°C (176°F) and 12V DC; 6,000 hours with an EWP®/Fan Digital Controller
Pump weight	900 grams (2.0 lb)
Pump material	Nylon 66, 30% glass-filled
Burst pressure	350 kPa (50 psi)
Seal	Ceramic face seal
Fits hose sizes	32mm to 51mm (1¼" to 2")



## Kit contents

Part #	Description	Qty
8105	EWP®80 Pump	1
8307	Straight adaptor	1
8309	Elbow adaptor	1
8509	O ring	2
8515	Wiring harness	1
8510	Sleeve 3mm rubber adaptors	2
8511	Sleeve 6mm	2
8512	Hose clamps	2
8908	Assorted hardware bag - includes relay #0533	1

## Options

Part #	Description	Qty
1025	Alloy adaptor - 1"	1 *
1026	Alloy adaptor - 1¼"	1 *
1027	Alloy adaptor straight - 26mm	1 *
1028	Alloy adaptor straight - 19mm	1 *

\* 2 required

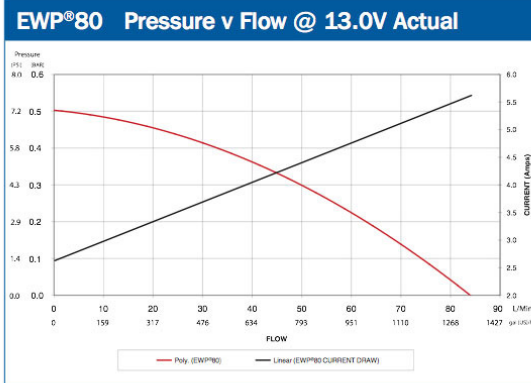

## Dimensions

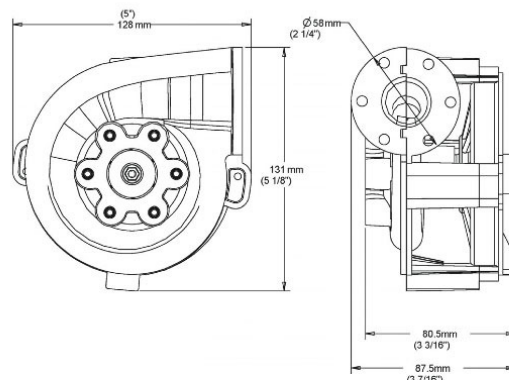

The EWP® is a recirculating pump which is ideal for a 'closed system' similar to an automotive cooling system; it is not 'self-priming'.

Page 14



## EWP80 Electric Water Pump

Part No: 8005

The revolutionary, Australian designed, EWP pump is made from anti-corrosive, lightweight, glass-filled nylon & incorporates a carbon mechanical face seal for added reliability. The EWP improves engine cooling control & capacity while giving you more power & improved fuel economy. The EWP is universal & fits almost all makes of vehicles on the road today. Included in the kit is everything you need to fit it to your vehicle.